

INSPIRED INNOVATION

Despatch
INDUSTRIES

**LCC/LCD2-14
OVEN SERIES WITH PROTOCOL 3™
OWNER'S MANUAL**

C-245
P/N 320208
VERSION 1
02/2013

SERVICE AND TECHNICAL SUPPORT

service parts: 1-800-473-7373
international service/main: 1-952-469-8230
service fax: 1-952-469-8193

service@despatch.com

GLOBAL HEADQUARTERS

phone: 1-888-DESPATCH (1-888-337-7282)
international/main: 1-952-469-5424
fax: 1-952-469-4513

sales@despatch.com
www.despatch.com

8860 207th Street West
Minneapolis, MN 55044 USA

Despatch
INDUSTRIES

MINNEAPOLIS • SHANGHAI • BERLIN • SINGAPORE • TAIPEI

Revision History—LCC/LCD2-14 Series

Revision	Date	Author	Description
A	7/2002		Initial creation.
B	11/2002		Drawing changes, add line connection detail.
C	8/2003		Update drawings.
D	11/2003		Updated to Protocol Plus Version 4.0.
E	3/2004		Update drawings, change Class A warning.
F	6/2004		Change water drain/outlet temp rating.
G	8/2006		Update to current design.
H	5/2007		Update drawings.
I	7/2007		General updates.
J	11/2007		Updated warranty.
K	9/2008		Added LL*1-* model reference.
L	3/2009		Updated Controller Instructions.
M	3/2010		Updated Declaration of Conformity.
1	2/2013	Livingston	Revised format and updated to Protocol 3. Version 4.

Copyright © 2013 by Despatch Industries.

All rights reserved. No part of the contents of this manual may be reproduced, copied or transmitted in any form or by any means including graphic, electronic, or mechanical methods or photocopying, recording, or information storage and retrieval systems without the written permission of Despatch Industries, unless for purchaser's personal use.

Table of Contents

1.	About This Manual.....	6
1.1.	Important User Information.....	6
1.2.	Manufacturer & Service	7
1.3.	Organization of this Manual	7
1.4.	Conventions.....	8
1.5.	Specifications	8
1.5.1.	Model Characteristics.....	8
1.5.2.	Dimensions	9
1.5.3.	Capacities	9
1.5.4.	Power.....	10
1.5.5.	Temperature.....	10
1.5.6.	Capability	11
2.	Safety.....	12
2.1.	Safety Information.....	12
2.1.1.	Lockout.....	12
2.1.1.1.	Lockout Requirements.....	12
2.1.1.2.	Lockout Procedure.....	12
2.1.2.	Door and Panel	12
2.2.	Maintenance	13
2.3.	Electrical Power.....	13
2.4.	Fire.....	13
2.5.	Equipment Lockout Requirements	14
2.5.1.	Main Disconnect Switch.....	14
2.5.2.	Manual Unlock	15
3.	Theory of Operation	16
3.1.	The LCC/LCD2-14 Series Oven	16
3.1.1.	LCC/LCD2-14 Oven Operation Details.....	16
3.1.1.1.	LCC/LCD2-14A (Class A) Operation Details.....	17
3.2.	The Protocol 3 Controller.....	18
3.3.	HEPA Filters	18
3.3.1.	Definitions	19
3.3.2.	Filter Packaging, Shipping and Handling.....	19
3.3.3.	HEPA Filter Validation Testing	20
3.3.3.1.	D.O.P. Testing	20
3.3.3.2.	Class 100 Testing	20
3.3.3.3.	Validation Testing	20
3.3.3.4.	HEPA Filter Burn-off Process.....	21
3.3.4.	HEPA Filter Unit Replacement	21
3.3.5.	HEPA Filter: Magnehelic Pressure Gauge	21
3.4.	Optional Beacon Light	22
4.	Assembly & Setup.....	23
4.1.	Unpack & Inspect The LCC/LCD Oven	23
4.1.1.	If Damaged During Shipping	23
4.2.	Setup The LCC/LCD2-14 Series Oven	23
4.2.1.	Select Oven Location	23
4.2.1.1.	Oven Placement Requirements.....	24
4.2.2.	Oven Utility Connections	24
4.2.2.1.	Nitrogen With Water-Cooled Models	25

4.2.2.2.	Air Atmosphere with Optional Water Cooling Model	26
4.2.3.	Exhaust Connections	28
4.2.4.	Wiring & Power Connections	29
4.3.	HEPA Filter Installation	31
4.3.1.	HEPA Filter Handling and Inspection.....	32
4.3.2.	HEPA Filter Burn-Off	36
4.3.2.1.	HEPA Filter Burn-Off Process	36
4.3.2.2.	Location of HEPA Filter Burn-Off Process.....	36
4.3.2.3.	Recommended HEPA Filter Burn-Off Process	36
4.3.3.	Filter High Limit Controller	37
4.3.3.1.	Reset the High Limit Controller	37
5.	Operation	38
5.1.	Load Oven	38
5.2.	Pre-Startup Checklist.....	39
5.3.	Operating Procedure	40
5.3.1.	Start The LCC/LCD2-14 Oven.....	40
5.3.2.	LCC/LCD2-14 Class A Oven Operation.....	41
5.3.3.	Working with Protocol 3 Operating Modes	41
5.3.4.	Sequence of Operation for LCC/LCD2-14 Ovens Equipped with Optional Beacon Light	41
5.3.5.	Sequence of Operation for Ovens Equipped for LCC/LCD2-14 Inert Atmosphere Oven.....	43
5.3.6.	Main Disconnect and Manual Unlock	44
5.3.6.1.	Main Disconnect Switch.....	44
5.3.6.2.	Manual Unlock	45
6.	Maintenance	46
6.1.	Checklist.....	46
6.2.	Maintenance Schedule.....	47
6.3.	Lubrication	48
6.4.	HEPA Filter Replacement	48
6.4.1.	Routine HEPA Filter Inspection.....	48
6.5.	Cleaning and Decontamination	48
6.5.1.	Cleaning the LCC2-14 Series Oven	48
6.5.2.	Decontaminating the LCC2-14 Series Oven	49
6.6.	Check High-Limit Controller	49
7.	Troubleshooting: Error Messages and Alarm.....	50
8.	Appendices	51
8.1.	HEPA Filter Pressure Reading Worksheet.....	51
8.2.	LCC/LCD2-14 Series Oven Options	52
8.2.1.	Optional MRC5000 Setup	52
8.2.2.	Optional High Limit Alarm with Alarm Silence	52
8.3.	Standard Products Warranty	54
8.4.	Electrical Schematics.....	54

Figures

Figure 1.	Main Disconnect Switch.	14
Figure 2.	Door Lock Manual Override Key (LCC/LCD).....	15
Figure 3.	LCC/LCD2-14 Series Oven.	16

Figure 4. Protocol 3 Operator Interface.....	18
Figure 5. This Side Up Graphic.....	19
Figure 6. Magnehelic Pressure Gauge Measures Pressure in Front of the HEPA Filter.	21
Figure 7. LCC/LCD2-14 Series Optional Beacon Light.	22
Figure 8. LCC/LCD2-14 Utility Connections.	25
Figure 9. Exhaust Connections.....	28
Figure 10. Line Connection.....	29
Figure 11. Conduit and Disconnect Switch/Line Connections.....	30
Figure 12. Example HEPA Filter (Silicone-free).....	32
Figure 13. LCC/LCD2-14 Side Panel.	33
Figure 14. Install HEPA high-temperature filter.....	34
Figure 15. Install HEPA standard filter.....	35
Figure 16. Typical High Limit controller. Note RESET button on right.	37
Figure 17. Power the LCC/LCD2-14 Oven.....	40
Figure 18. Class A Nameplate Example.....	41
Figure 19. Nitrogen Flowmeter.	43
Figure 20. Adjust Nitrogen needle valve (in compartment beneath oven).....	44
Figure 21. Main Disconnect Switch.	44
Figure 22. Door Lock Manual Override Key (LCC/LCD).....	45
Figure 23. Alarm Silence Switch.....	53
Figure 24. LCC/LCD2-14 (Drawing 320905-01).....	55
Figure 25. LCC/LCD2-14 (Drawing 320905-02).....	55
Figure 26. LCC/LCD2-14 (Drawing 320905-03).....	55
Figure 27. LCC/LCD2-14 (Drawing 320905-04).....	55

Tables

Table 1. LCC/LCD2-14 Series Oven Model Characteristics.	8
Table 2. Electrical Specifications.....	10
Table 3. Utility Connections (Refer to Figure 8).....	24
Table 4. Exhaust Connection Requirements.....	28
Table 5. Error Messages and Next Steps.....	50
Table 6. HEPA Filter Pressure Reading Worksheet.....	51
Table 7. MRC 5000 Settings.	52

1. About This Manual

1.1. Important User Information

Copyright © 2013 by Despatch Industries.

All rights reserved. No part of the contents of this manual may be reproduced, copied, or transmitted in any form or by any means including graphic, electronic, or mechanical methods or photocopying, recording, or information storage and retrieval systems without the written permission of the publisher, unless it is for the purchaser's personal use.

Printed and bound in the United States of America.

The information in this manual is subject to change without notice and does not represent a commitment on the part of Despatch Industries. Despatch Industries does not assume any responsibility for any errors that may appear in this manual.

In no event will Despatch Industries be liable for technical or editorial omissions made herein, nor for direct, indirect, special, incidental, or consequential damages resulting from the use or defect of this manual.

	<p>Values displayed on screens are examples only. Though those values may be typical, contact Despatch Industries for the final value.</p>
--	---

	<p>Users of this equipment must comply with operating procedures and training of operation personnel as required by the Occupational Safety and Health Act (OSHA) of 1970, Section 5 and relevant safety standards, as well as other safety rules and regulations of state and local governments. Refer to the relevant safety standards in OSHA and National Fire Protection Association (NFPA), section 86 of 1990.</p>
---	--

	<p>Danger!</p> <p>Only fully-trained and qualified personnel should setup and maintain this equipment. Improper setup and operation of this equipment could cause an explosion that may result in equipment damage, personal injury or possible death.</p>
---	--

The information in this document is not intended to cover all possible conditions and situations that might occur. The end user must exercise caution and common sense when installing or

Copyright © 2013 by Despatch Industries.

All rights reserved. No part of the contents of this manual may be reproduced, copied or transmitted in any form or by any means including graphic, electronic, or mechanical methods or photocopying, recording, or information storage and retrieval systems without the written permission of Despatch Industries, unless for purchaser's personal use.

maintaining Despatch Industries products. If any questions or problems arise, call Despatch Industries at **1-888-DESPATCH** or **1-952-469-5424**.

1.2. **Manufacturer & Service**

The LCC/LCD2-14 Series oven is manufactured by Despatch Industries.

Despatch has specialized in thermal processing for over 100 years. Technical expertise gained over those years helps provide innovative solutions to critical applications in vertical markets and cutting edge technology worldwide. Despatch products are backed by a drive for long-term customer satisfaction and a strong sense of responsibility. The worldwide network of factory-trained Service Professionals is available to support your Despatch equipment. From full service preventive maintenance to routine repair and certified calibration and uniformity, the Despatch service network is positioned to respond to your business needs. Our service programs are customized to meet your specific needs using our Advantage Service Assurance Program (ASAP). For more information on ASAP, visit **www.despatch.com**.



Global Headquarters	Contact	Service & Technical Support
Despatch Industries 8860 207th Street Lakeville, MN 55044 USA	International/Main: 1-952-469-5424 US toll free: 1-888-337-7282 Fax: 1-952-469-4513 info@despatch.com www.despatch.com	Service: 1-952-469-8230 US toll free: 1-800-473-7373 Service @despatch.com

1.3. **Organization of this Manual**

This owner's manual contains the most comprehensive set of information for the Despatch LCC/LCD2-14 Series ovens, including installation instructions, theory of operation, operating instructions, among other things.

	<p><i>Danger!</i></p> <p><i>Failure to heed warnings in this instruction manual and on the oven could result in personal injury, property damage or death.</i></p>
---	--

1.4. Conventions

	<i>This icon signifies information that describes an unsafe condition that may result in death, serious injury, or damage to the equipment.</i>
Danger!	<i>Danger is the signal word used to indicate a hazardous situation that, if not avoided, will result in death or severe injury.</i>
Warning!	<i>Warning is the signal word used to indicate a hazardous situation that, if not avoided, could result in death or severe injury.</i>
Caution!	<i>Caution is the signal word used to indicate a hazardous situation that, if not avoided, could result in moderate or minor injury.</i>
Notice	<i>Notice is the signal word used to indicate a hazardous situation that, if not avoided, could result in property damage.</i>
	<i>This icon signifies supplemental important information.</i>
LOG OUT	<i>Bold, 10 point sans-serif typeface indicates a specific key or button on screen to click.</i>

1.5. Specifications

1.5.1. Model Characteristics

Table 1. LCC/LCD2-14 Series Oven Model Characteristics.

Model	Atmosphere	Max Temp °C	Seals
LCC2-14	Air	260	Silicone
LCC2-14V-4	Air	260	Silicone Free
LCD2-14	Air	350	Silicone
LCD2-14V-4	Air	350	Silicone Free
<hr/>			
LCC2-14N-4	Inert	260	Silicone
LCC2-14NV-4	Inert	260	Silicone Free
LCD2-14N-4	Inert	350	Silicone
LCD2-14NV-4	Inert	350	Silicone Free
<hr/>			
LCC2-14A-4	Class A	260	Silicone
LCC2-14AV-4	Class A	260	Silicone Free
LCD2-14A-4	Class A	350	Silicone
LCD2-14AV-4	Class A	350	Silicone Free

Copyright © 2013 by Despatch Industries.

All rights reserved. No part of the contents of this manual may be reproduced, copied or transmitted in any form or by any means including graphic, electronic, or mechanical methods or photocopying, recording, or information storage and retrieval systems without the written permission of Despatch Industries, unless for purchaser's personal use.

1.5.2. Dimensions

Models	Chamber Size inches (cm)			Capacity ft ³ (liters)	Overall Size inches (cm)			Maximum number of Shelves
	W	D	H		W	D	H	
LCC/LCD2-14	25.5 (64)	26 (66)	37 (94)	14 (396)	47.5 (121)	41.5 (105)	71 (180)	11



The LCC/LCD2-14 oven is not intended to process solvents or other volatile or flammable materials. Oven forced exhaust is intended for cooling purposes only on standard and inert (nitrogen) models.

Order an LCC/LCD2-14 oven with the Class A option to process solvents or other volatile or flammable materials.

1.5.3. Capacities

Models	LCC/LCD2-14
Maximum Load (Lbs) (KG)	400 181
Maximum Shelf Capacity (Lbs) (KG)	50 23
Recirculating fan (CFM/LPS) (H.P.)	950/448 1.5
Net weight (Approximate) (Lbs) (KG)	955 434
Shipping weight (Approximate) (Lbs) (KG)	1050 477
Exhaust fan (CFM/LPS) (HP)	85/40 0.03
Exhaust Opening Diameter (Inch) (mm)	4 101.6

* Clear opening width is reduced by 1.5 inches (3.8cm) due to ¾ inch (1.9cm) shelf supports on each side.

Copyright © 2013 by Despatch Industries.

All rights reserved. No part of the contents of this manual may be reproduced, copied or transmitted in any form or by any means including graphic, electronic, or mechanical methods or photocopying, recording, or information storage and retrieval systems without the written permission of Despatch Industries, unless for purchaser's personal use.

1.5.4. Power

If the line voltage for your LCC/LCD2-14 Series oven varies more than 10% from the oven voltage rating, electrical components such as relays and temperature controls may operate erratically. Power connection is performed by the user.

- If the line voltage is lower than the oven voltage rating, heat-up time may be significantly longer and motors may overload or run hot
- If the line voltage is higher than the nameplate rating, motors may run hot and draw excessive amperage

Table 2. Electrical Specifications.

Models	Volts	Amps	Phase	Hertz	Heater (kW)
LCC/LCD2-14	208	50.5	3	50/60	16
	240	44.5	3	50/60	16
	380	21.6	3	50	12
	415	25.2	3	50	16
	480	22.2	3	60	16

1.5.5. Temperature

Model		LCC/LCD2-14
Time to Temperature (approximate minutes) (no load)	50°C – 100°C	3 min.
	50°C – 200°C	9 min.
	50°C – 260°C	15 min.
	50°C – 350°C [†]	35 min.
Cooling Time to Temp Minutes (No Load) ^{‡§}	100°C – 65°C	41 min. (air atmos.) 15 min. (nitrogen atmos.) [§]
	175°C – 65°C	82 min. (air atmos.) 20 min. (nitrogen atmos.) [§]
	260°C – 65°C	95 min. (air atmos.) 25 min. (nitrogen atmos.) [§]
	350°C – 65°C [†]	116 min. (air atmos.) 30 min. (nitrogen atmos.) [§]
Temperature Uniformity at ^{**}	100°C	±1°C
	175°C	±2°C
	260°C	±3°C
	350°C [†]	±3.5°C
Maximum Operating Temperature	LCC	260°C

[†] For LCD only, LCC maximum temperature: 260°C.

[‡] Minimum operating temperatures and cooling times are based on a 20°C ambient temperature measured at the fresh air inlet.

[§] Based on cooling water supplied at 3 GPM (11 lpm), 13°C (55°F).

^{**} Uniformity figures are based on a nine-point test conducted in an empty oven after stabilization period. Uniformity can vary slightly depending on unit and operating conditions. Class 100 HEPA filtration will limit ramp rates. Specifications are subject to change without notice.

Model	LCC/LCD2-14	
	LCD	350°C
Operating Range w/20°C Ambient	LCC	50°C-260°C (air atmos.) 30°C-260°C (nitrogen atmos.)
	LCD	50°C-350°C (air atmos.) 30°C-350°C (nitrogen atmos.)
Control Stability		±0.5°C

1.5.6. Capability

The standard LCC/LCD2-14 Series oven is not available for Class A flammable solvent environments. However LCC/LCD2-14 Class A ovens are specifically designed for NFPA 86 Class A requirements in which flammable solvents are present. They include a pressure relief panel, purge timer and exhaust fan. Please note the solvent handling capabilities and do not exceed those capabilities.

The ovens have an explosion relief panel and purge interlock devices:

- If the LEL (Lower Explosive Limit) is exceeded and an explosive mixture is ignited in the oven, the explosion relief will rupture, preventing any more physical damage to the oven.
- An airflow switch on the exhaust to verify exhaust fan is operating.
- A purge timer preset to keep heater off until the purge period is complete. The preset purge period guarantees four complete air exchanges to remove volatiles in the chamber before the heater can be turned on.
- Any failure of these devices will shut down the heater, preventing further processing until the condition is remedied.



The LCC/LCD2-14A Class A option requires the exhaust fan be wired ON at all times.



Danger!

LCC/LCD2-14A Class A ovens are designed for a specific amount of solvent. Exceeding this amount could result in an explosion. Do not process closed containers of any substance or liquid in this oven because they may explode under heat. In case of fire, leave door(s) as they are. Shut off electricity. Shut off fuel. Call the fire department. Stay away.

2. Safety

2.1. Safety Information

Do not work on the LCC/LCD2-14 Series oven without reading and understanding this section which contains important information and warnings. Ignoring these warnings can result in death, serious injury or damage to the machine and product.

2.1.1. Lockout

Machine lockout places the LCC/LCD2-14 Series oven into a zero energy state and prevents accidental machine start up. Always follow the Lockout Procedure described in this Section before cleaning, maintaining or repairing the LCC/LCD2-14 Series oven. An accidental start-up, while working on the LCC/LCD2-14 Series oven, can result in serious injury or death.

2.1.1.1. Lockout Requirements

1. Every power source that can energize any element of the LCC/LCD2-14 Series oven must be shut off at the closest possible power source. This includes air, water and electricity, including the Disconnect Switch.
2. After energy sources are locked out, test to ensure circuits are de-energized.

2.1.1.2. Lockout Procedure

Personnel authorized to lockout equipment must have the necessary locks to perform the lockout.

1. Physically disconnect all electrical power to the machine or lockout the appropriate breaker or disconnects.
2. Close all valves and bleed off any pressure.
3. Test for power by attempting a start with the machine controls.
4. Identify the Lockout Condition with a tag on the electrical disconnect and pneumatic shut off valve.
5. When work is complete, remove all tags and restore the machine to its working state.

	<p>Danger!</p> <p><i>Electrical panels contain high voltage. Disconnect and lock out the power supply before working inside any electrical panels. Failure to lock out the power supply can result in death or injury.</i></p>
---	---

2.1.2. Door and Panel

The door and rear panel on the LCC/LCD2-14 Series oven protect against hazards. Power is required to open the door and the oven heater must be OFF when the door is open. Operation

without these safety devices in place creates hazards that the doors and covers are intended to render safe for personnel.

The door requires a Manual Override Key for use when power is off. The door and panel that require a tool to open are part of the safety system of the LCC/LCD2-14 Series oven. Do not open the door while the machine is running.

The LCC/LCD2-14 is also equipped with a door switch which turns off the heater when the door is opened.

2.2. Maintenance

Only qualified and trained personnel should perform maintenance or repair.

	<p><i>Danger!</i></p> <p><i>Electrical panels contain high voltage. Disconnect and lock out the power supply before working inside any electrical panels. Failure to lock out the power supply can result in death or injury.</i></p>
---	---

2.3. Electrical Power

Only qualified and trained personnel should perform electrical maintenance or electrical repair.

	<p><i>Danger!</i></p> <p><i>Contact with energized electrical sources may result in serious injury or death.</i></p>
---	--

- Before performing maintenance, disconnect all electrical power from the machine. Use a padlock and lockout all disconnects feeding power to the machine.
- Never clean, or repair the oven when in operation.
- Unauthorized alterations or modifications to the LCC/LCD2-14 Series oven are strictly forbidden. Never modify any electrical circuits. Unauthorized modifications can impair the function and safety of the LCC/LCD2-14 Series oven.

2.4. Fire

Keep the LCC/LCD2-14 Series oven clean and free of scrap materials, oil or solvents to prevent the possibility of fire.

1. Leave door as is.

2. De-energize the machine immediately by turning OFF the **DISCONNECT SWITCH** (if applicable).
3. Turn off the remote main disconnect (customer supplied disconnect).
4. Shut off fuel.
5. Call the fire department.
6. Stay away.

	<p>Danger!</p> <p><i>Always disconnect all power before extinguishing a fire. Attempting to extinguish a fire in a machine connected to electrical power can result in serious injury or death.</i></p>
---	--

2.5. Equipment Lockout Requirements

To prevent injury or equipment damage during inspection or repair, the LCC/LCD2-14 Series oven must be locked out.

2.5.1. Main Disconnect Switch

When a risk of personal injury or damage to the LCC/LCD2-14 Series oven exists, turn OFF the **DISCONNECT SWITCH** on the front of the oven (Figure 1). The **DISCONNECT SWITCH** shuts off all electrical power to the oven.



Figure 1. Main Disconnect Switch.

2.5.2. Manual Unlock

If a power failure occurs insert a torx tip tool (provided) and rotate 90 degrees counterclockwise to allow the chamber door to open. The tool must be turned back to the locked position to allow electrical operation again.



To check door and latch for smooth operation, use a hollow point torx tip tool and rotate 90 degrees counterclockwise the manual override in the safety switch. It must be turned back to the locked position to allow electrical operation.



Warning!

The LCC/LCD2-14 door requires a Manual Override Key for use when power is OFF. The door and panel that require a tool to open are part of the safety system of the LCC/LCD2-14 Oven. Do not attempt to permanently mount the Manual Override Key.



Do not remove torx screw from door release mechanism. Manual Override Key cannot be permanently mounted.

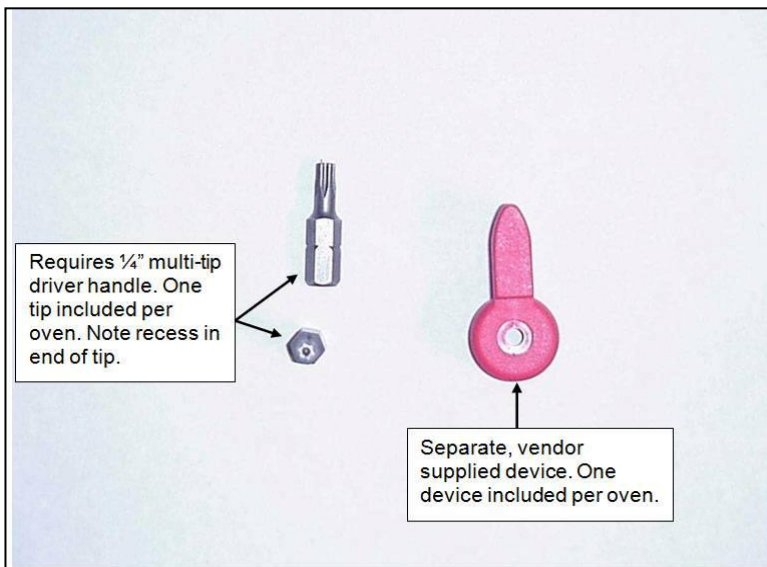

Figure 2. Door Lock Manual Override Key (LCC/LCD).

3. Theory of Operation

3.1. The LCC/LCD2-14 Series Oven

The LCC/LCD2-14 Series oven (Figure 3), a class 100 clean room oven, offers HEPA (High Efficiency Particulate Air) filtration for processes where minimized contamination is essential. Forced convected airflow provides rapid uniform distribution of heat. The removable HEPA filter is designed to provide a constant flow of 99.97% clean air to the product being heated. The HEPA filter with silicone seal provides 99.99% filtration. A magnehelic differential pressure gauge monitors pressure drop across the HEPA filter.

The oven operator interface is located on the hinged control panel at the front of the oven (Figure 3). Power components, fuse blocks and motor starters are located on the equipment panel, behind the hinged control panel, for easy access (Figure 8). The transformer and the heater SSR's are located in the lower compartment with the recirculation and exhaust/cooling motors. Electrical components are either touch-proof or are shielded with Lexan[®] material to prevent accidental exposure during maintenance and troubleshooting.

The cooling/exhaust fan is controlled on/off by an event relay in the Protocol 3 controller. The cooling fan is used for rapid cool-down at the end of the process cycle, or to maintain low temperature setpoints during process cycle. It may also be turned on at the start of a process cycle to assure that starting temperature is less than 70°C.

The oven has a type 304-2B stainless steel interior. All interior seams are continuously welded on the insulation side. This protects the work chamber from contaminated air and permits chamber washing without damaging the insulation. Interior ductwork may be easily removed for cleaning. Heater frame, fan wheel and motor shaft are constructed of stainless steel.

Two electropolished stainless steel wire shelves are provided. The shelves are removable and adjustable on three inch centers.

The optional Despatch Protocol Manager software is used to enable customer PC control of an oven. Despatch Protocol 3 controllers may be networked together with a Modbus communication option when multiple ovens are operated.



Figure 3. LCC/LCD2-14 Series Oven.

3.1.1. LCC/LCD2-14 Oven Operation Details

The LCC/LCD2-14 ovens are available with air, inert (nitrogen) or Class A atmospheres. LCC models are rated up to 260°C, and LCD models are rated up to 350°C. Silicone free construction is available on all models.

The LCC2-14 Series ovens have an electrical door lock that prevents the operator from opening the chamber door when a cycle is in process. The door lock is de-energized at the end of a cycle or when power is off.

The nitrogen models have a Type 316 stainless steel water coil which permits rapid cool-down and lower temperature operation. The nitrogen oven comes with a flowmeter for adjusting purge rate, a needle valve for setting maintain rate, separate solenoid valves for purge and maintain operation and a pressure relief exhaust port. An exhaust fan which powers ON whenever the oven is running maintains consistent chamber pressure control with varied exhaust stack conditions.

	<p>Danger!</p> <p><i>Use care when working with nitrogen. Nitrogen presents an asphyxiation hazard. Handle nitrogen according the safe handling procedures listed in the material safety data sheet.</i></p>
---	---

3.1.1.1. LCC/LCD2-14A (Class A) Operation Details

The exhaust fan event relay is hardwired in the ON position for Class A ovens to remove volatiles. The exhaust fan must remain on at all times. A water cooling option is also available for faster cool-down times.

	<p><i>The exhaust fan of a Class A oven must remain on at all times.</i></p>
---	--

The LCC/LCD2-14A Class A oven is specifically designed for Class A NFPA 86 requirements in which flammable solvents are present. They include a pressure relief panel, purge timer and exhaust fan. Please note the solvent handling capabilities and do not exceed those capabilities.

	<p>Danger!</p> <p><i>LCC/LCD2-14A Class A ovens are designed for a specific amount of solvent. Exceeding this amount could result in an explosion. Do not process closed containers of any substance or liquid in this oven because they may explode under heat. In case of fire, leave door(s) as they are. Shut off electricity. Shut off fuel. Call the fire department. Stay away.</i></p>
---	---

3.2. The Protocol 3 Controller

The Protocol 3 is a microprocessor based digital temperature controller designed for simple and flexible oven operation (Figure 4). The Protocol 3 controller operates as a dual-functioning controller/High Limit instrument. The control portion utilizes a time-proportioning voltage signal to control heating devices with minimal temperature fluctuations.

The High Limit portion protects the product and/or the oven from overheating. If the product being processed has a critical high temperature limit, the High Limit setpoint should be set to a temperature somewhat below the temperature at which the product could be damaged. If the product does not have a critical high temperature limit, the High Limit setpoint should be set 5 to 15 degrees higher than the maximum programmed setpoint at which the oven will operate.

The Protocol 3 controller provides three primary operating modes:

- Manual: Oven operates continuously at a fixed temperature until turned off.
- Timer: Oven operates at a fixed temperature for a user-selected time period, and then automatically turns off.
- Profile: Temperatures increase or decrease as defined by 255 segments that can be allocated to 64 ramp and soak profiles. The profiles can be linked to provide additional temperature combinations.

Review the Protocol 3 Controller Owner's Manual for more information.



Figure 4. Protocol 3 Operator Interface.

3.3. HEPA Filters

The LCC/LCD2-14 Series ovens use HEPA (High Efficiency Particulate Air) filters to limit particulate size in the work chamber to 0.3 microns or less. Two different types of filters are typically used. While both filters are high-temperature filters in that they are designed for use in thermal processing equipment, the “standard” HEPA filter is rated to 260°C (500°F) while the “high-temperature” HEPA filter is rated to 350°C (662°F).

	<p>LCC oven chamber temperature transitions must not exceed 1.5°C/minute to maintain class 100 chamber conditions. For ramp rates greater than 1.5°C/minute and up to 5°C/minute, the LCD model will maintain class 100 chamber conditions.</p>
---	--

3.3.1. Definitions

- **Binder:** Organic substance used in filter construction to provide the media with structural strength.
- **Burn-Off:** Process for eliminating the binder contained in the filter.
- **D.O.P.:** Dioctyl Phthalate - Aerosol particles of submicron size used in testing phase to spot defects or measure filter efficiency.
- **HEPA:** High Efficiency Particulate Air

	<p>Despatch does not recommend using D.O.P. or other organic challenge agents.</p>
---	---

3.3.2. Filter Packaging, Shipping and Handling

Packaging practice varies among the filter unit manufacturers. Filter units are typically packaged in cardboard cartons with varying approaches for strengthening the container and making it impact-resistant. Shipping cartons are typically marked with a vertical arrow and "This Side Up" (Figure 5). A filter unit is placed in the carton so the pleated folds are vertical (running from top to bottom), versus side to side.



THIS SIDE UP

Figure 5. This Side Up Graphic.

	<p>Ship, handle, store and install HEPA filters with pleats positioned vertically. Horizontally-positioned pleats risk breaking at the adhesive line of the filter medium. Horizontally-positioned pleats also collect entrapped material on "shelves." The accumulated weight of the entrapped material may cause sag and lead to early failure of the filter unit.</p>
---	---

The filter is typically shipped in the original carton or package provide by the filter manufacturer. This carton or package provides good storage and maximum protection from dirt and moisture. Store and move HEPA filters upright in the shipping carton. Minimize handling of the filter. During installation, remove the filter from the shipping carton and install directly into the oven.

If an unpackaged HEPA filter unit must be placed with its face on the floor or other surface, clear the surface entirely of every object or irregularity which might damage the filter pack.

3.3.3. HEPA Filter Validation Testing

Despatch Industries guarantees the HEPA filters will meet specified efficiency ratings when the following recommendations are followed:

- The filter is properly installed
- The filter is run at or below 180°C, at a constant temperature
- The filter is burned off at 260°C for 48 hours before running

3.3.3.1. D.O.P. Testing

	<p>Caution!</p> <p><i>Despatch does not recommend D.O.P. filter testing.</i></p>
---	---

D.O.P. testing uses aerosol particles of submicron size to spot defects or measure filter efficiency. Degenerative by-products of this test are distributed throughout the oven chamber upon heat-up. These and other organic challenge agents present a fire hazard for LCC/LCD2-14 Non-Class A (NFPA 86) ovens. Despatch does not recommend D.O.P. filter testing.

3.3.3.2. Class 100 Testing

Despatch guarantees a Class 100 environment within the oven. This classification is based on measurement of the particulate level within the oven work chamber.

Class 100 testing may be performed before or after a proper filter burn-off procedure has been performed. Despatch guarantees Class 100 condition measurements based on two methods of test. The direct method employs an extraction-type particulate analyzer. The indirect method involves particle settling over a specified period of time onto a clean disk. Please consult factory for expected levels.

3.3.3.3. Validation Testing

Despatch recommends the following test sequence for pharmaceutical Class 100 ovens.

1. Proper installation of the HEPA filters (Section 4.3).
2. Ambient air challenge to determine integrity of oven chamber and filter gaskets.
3. Proper filter burn-off procedure.
4. Class 100 testing inside the work chamber.

3.3.3.4. HEPA Filter Burn-off Process

HEPA filters contain a binder material which protects the filter media during production and shipping. Smoke produced from burning this binder at elevated temperatures is undesirable during normal oven operation. Burning off the binder will ensure a clean process at elevated temperatures.

However, when the binder is burned out of the filter media, the filter becomes very fragile: too fragile to withstand normal shipping and handling. For this reason, Despatch does not perform the burn-off procedure. The burn-off process is not necessary at temperatures consistently under 180°C.

3.3.4. HEPA Filter Unit Replacement

Periodically replace the HEPA filter unit due to:

- Resistance, or pressure drop, across the filter unit. Maximum level of resistance in inches (water gauge) will vary depending upon the operation of the filter and the available fan capacity. Adequate fan capacity must be available.
- Loss of efficiency (leakage), determined from air-sampling measurements made downstream of the filter unit.
- Visible damage or rupture of the filter media in a unit.
- Change in process application.
- Excessive build-up of lint or combustible particulate matter on the filter unit.
- Water droplets in airstream through filter, free water (RH = 100%), will saturate filter very quickly and may cause burnout or holes in burned off filter media.

3.3.5. HEPA Filter: Magnehelic Pressure Gauge

The LCC Series oven is equipped with a Magnehelic pressure gauge which measures the pressure in front of the HEPA filter (Figure 6). As the filter becomes dirty, pressure increases. Despatch recommends changing the filter when the pressure is 1" w.c. greater than when the filter was first installed (Refer to Section 4.3 for filter replacement).

Since pressure can be affected by many factors involved in the installation, it is important to record the pressure of a new filter as a baseline. Recorded pressure readings allow for new readings to be periodically checked against this baseline. Use Table 6 for recording this information (See Section 8.1 for a blank worksheet).



Figure 6. Magnehelic Pressure Gauge Measures Pressure in Front of the HEPA Filter.

For a nitrogen atmosphere oven, pressure readings also give an indication of the integrity of the seals. If the pressure recorded in Columns D or E decrease over time, inspect the oven seals.

3.4. *Optional Beacon Light*

The LCC/LCD2-14 Series beacon light option provides visual cycle process indication to the operator (Figure 7). The beacon light option is on the front control panel of both the LCC/LCD2-14PT-3 Pass-Through oven and the standard LCC/LCD2-14 oven.



Figure 7. LCC/LCD2-14 Series Optional Beacon Light.

The beacon light provides visual indication of the cycle status as follows:

- Green: Cycle in process
- Yellow: Standby. Operator has unloaded product. Oven waiting for next cycle.
- Red: Error or fault condition.

4. Assembly & Setup

Assembly and Setup provides directions for unpacking and installing your LCC/LCD2-14 Series oven.

4.1. Unpack & Inspect The LCC/LCD Oven

Remove all packing materials and thoroughly inspect the oven for any damage that might have occurred during shipment.

- Note the condition of the carton and plastic cover sheet inside the carton.
- Observe all outside surfaces and corners of the oven for scratches and dents.
- Check oven controls and indicators for normal movement, bent shafts, cracks, chips or missing parts such as knobs and lenses.
- Check the door and latch for smooth operation.
- Check the filter carton for damage



To check door and latch for smooth operation, use a hollow point torx tip tool and rotate 90 degrees counterclockwise the manual override in the safety switch. It must be turned back to the locked position to allow electrical operation.

4.1.1. If Damaged During Shipping

If damage occurred during shipping:

1. Contact the shipper immediately and file a written damage claim.
2. Contact Despatch Industries (1-800-473-7373 or 1-952-469-8230 or service@despatch.com) to report your findings and to order replacement parts for those damaged or missing. Send a copy of your filed damage claims to Despatch Industries (**Despatch Industries, 8860 207th Street, Lakeville, MN 555044, USA**).
3. Check the packing list to ensure you received all the specified components of the oven system. If any items are missing, contact Despatch Industries to have missing products forwarded to you.
4. Complete the warranty card and mail it to Despatch within 15 days after receipt of the equipment.

4.2. Setup The LCC/LCD2-14 Series Oven

4.2.1. Select Oven Location



Danger!

LCC/LCD2-14A Class A ovens are designed for a specific amount of solvent. Exceeding this amount could result in an explosion. Do not process closed containers of any substance or liquid in this oven because they may explode under heat. In case of fire, leave door(s) as they are. Shut off electricity. Shut off fuel. Call the fire department. Stay away.

Copyright © 2013 by Despatch Industries.

All rights reserved. No part of the contents of this manual may be reproduced, copied or transmitted in any form or by any means including graphic, electronic, or mechanical methods or photocopying, recording, or information storage and retrieval systems without the written permission of Despatch Industries, unless for purchaser's personal use.

	<p>Warning!</p> <p><i>Do not use the oven in wet, corrosive or explosive atmospheres unless this oven is specifically designed for a special atmosphere.</i></p>
---	---

4.2.1.1. Oven Placement Requirements

- The LCC/LCD2-14 Series oven has a four inch diameter exhaust opening.
- The oven may be placed next to another cabinet on its right, or next to another oven, with three-quarters of an inch (19mm) clearance (measure with door open).
- Exhaust air may reach 260°C on the LCC version and 350°C on the LCD version. Make sure exhaust piping materials can withstand these temperatures.
- LCC/LCD2-14 oven exhaust opening is on the rear of the oven.
- Plumb and level the oven to assure proper heat distribution and operation of all mechanical components.
- Leave room at the oven sides and rear for maintenance.
- The rear of the oven may be placed against a wall (with proper spacing).

	<p><i>The rear of a LCC/LCD2-14 Series Class A oven must have a minimum of six inches of clearance between the oven and any wall for explosion relief.</i></p>
---	--

4.2.2. Oven Utility Connections

Utility connections vary slightly on different LCC/LCD models. Table 3 lists the connection purposes and parameters. Refer to Figure 8 for a visual reference.

Table 3. Utility Connections (Refer to Figure 8).

Connection	LCC/LCD Air Atmosphere models with optional water-cooling	LCC/LCD Nitrogen Atmosphere models with standard water-cooling
NITROGEN INLET	<ul style="list-style-type: none"> • Clean Dry Air Inlet (70-80 psi (4.83-5.52 bar)) • Used to purge water from coil prior to heating oven • 3/8" NPT female brass connections provided 	<ul style="list-style-type: none"> • Nitrogen Inlet (70-80 psi (4.83-5.52 bar)) • Purge nitrogen, clean dry air and water from coil prior to heating the oven • 3/8" NPT female brass connections provided
WATER OUTLET	<ul style="list-style-type: none"> • During cooling cycle, water flows through the water coil and out this connection • 3/8" NPT female brass connections provided • Piping must be rated for up to 125°C (257°F) 	

Copyright © 2013 by Despatch Industries.

All rights reserved. No part of the contents of this manual may be reproduced, copied or transmitted in any form or by any means including graphic, electronic, or mechanical methods or photocopying, recording, or information storage and retrieval systems without the written permission of Despatch Industries, unless for purchaser's personal use.

Connection	LCC/LCD Air Atmosphere models with optional water-cooling	LCC/LCD Nitrogen Atmosphere models with standard water-cooling
WATER DRAIN	<ul style="list-style-type: none"> At the end of a cooling cycle, Nitrogen or Clean Dry Air is purged through the water coil. Water and pressurized nitrogen/air exit this connection for 30 seconds. Must be connected to gravity style drain (no backpressure). 3/8" NPT female brass connections provided Piping must be rated for up to 125°C (257°F) 	
WATER INLET	<ul style="list-style-type: none"> Water Inlet for cooling 3/8" NPT female brass connections provided Requires 3 GPM (11 LPM) flow at 13°C (55°F) to meet published cooling rates Maximum Pressure 100 PSI (6.89 Bar) 	

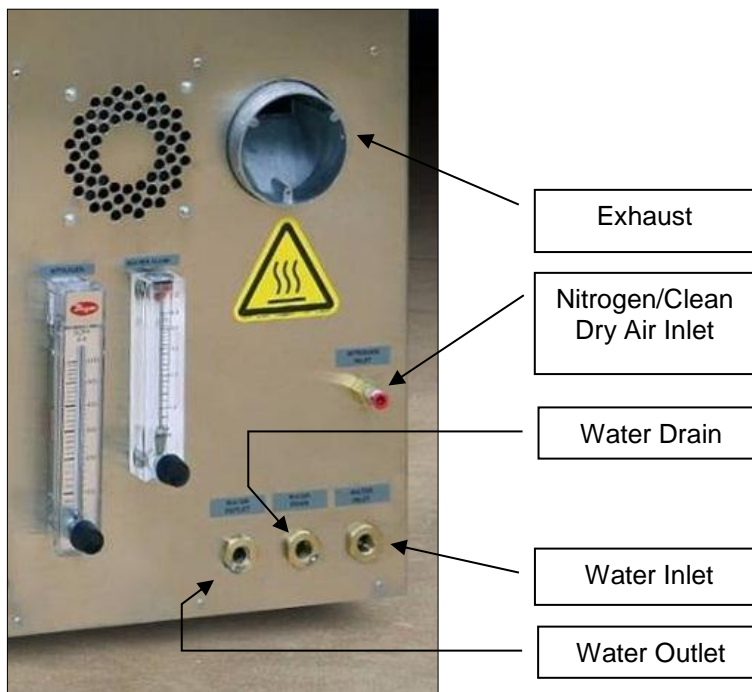



Figure 8. LCC/LCD2-14 Utility Connections.

4.2.2.1. Nitrogen With Water-Cooled Models

1. Connect nitrogen supply line to **NITROGEN INLET** on the side of the oven (Figure 8).

	<p><i>Nitrogen pressure supplied should run at 70 psi (4.83 bar) but not more than 80 psi (5.52 bar). Check for leaks.</i></p>
---	---

2. Install water connection for cooling coils to **WATER INLET** (Figure 8). Verify the valve on the flowmeter is turned OFF, that is, fully clockwise.

	<p>Water pressure supplied to the oven must not exceed 100 psi (6.89 bar). Despatch recommends installing a regulator to prevent surging.</p>
---	--

3. Check for leaks by slowly opening the valve on the flowmeter and allowing any air to bleed out.

	<p>Caution!</p> <p>Failure to allow air to bleed from the flowmeter may damage the flowmeter. Bleed air from the flowmeter after every instance of shutting off the water supply.</p>
---	---

4. Adjust the flowmeter to the recommended 3 gpm (11.4 lpm).
5. Make the drain connection at the rear of the oven. Note there are two drain connections: **WATER OUTLET** and **WATER DRAIN** (Figure 8).

	<p>WATER DRAIN must be left open-to-atmosphere. Make closed-loop connections using WATER OUTLET (Figure 8).</p>
--	--

	<p>Warning!</p> <p>Never allow WATER DRAIN to be plugged. A hot oven generates a small amount of steam when the water is first turned on. Steam can burn skin.</p>
---	--

	<p>Caution!</p> <p>Design the drain system to prevent operator injury from high temperature or pressure buildup. Piping must be able to withstand short periods of up to 343°C (650°F). Insulate drain lines and/or install warning labels stating the potential high temperature or pressure hazard.</p>
---	---

4.2.2.2. Air Atmosphere with Optional Water Cooling Model

1. Install water connection for cooling coils to **WATER INLET** (Figure 8). Verify the valve on the flowmeter is turned OFF, that is, fully clockwise.



Water pressure supplied to the oven must not exceed 100 psi (6.9 bar). Despatch recommends installing a regulator to prevent surging.

2. Check for leaks by slowly opening the valve on the flowmeter and allowing any air to bleed out.



Caution!

Failure to allow air to bleed from the flowmeter may damage the flowmeter. Bleed air from the flowmeter after every instance of shutting off the water supply.

3. Adjust the flowmeter to the recommended 3 gpm (11.4 lpm).
4. Make the drain connection at the side of the oven. Note there are two drain connections: **WATER OUTLET** and **WATER DRAIN** (Figure 8).
5. Connect the compressed air supply line to the **DRY AIR** inlet.



Compressed air supplied should run at 70 psi (4.83 bar) but not more than 80 psi (5.52 bar). Check for leaks.



WATER DRAIN must be left open-to-atmosphere. Make closed-loop connections using WATER OUTLET (Figure 8).



Warning!

Never allow WATER DRAIN to be plugged. A hot oven generates a small amount of steam when the water is first turned on. Steam can burn skin.



Caution!

Design the drain system to prevent operator injury from high temperature or pressure buildup. Piping must be able to withstand short periods of up to 343°C (650°F). Insulate drain lines and/or install warning labels stating the potential high temperature or pressure hazard.

4.2.3. Exhaust Connections

The LCC/LCD2-14 Series oven exhaust port is located on the rear of the oven (Figure 9). Table 4 lists the requirements for the exhaust stack for the LCC/LCD2-14 Series oven.

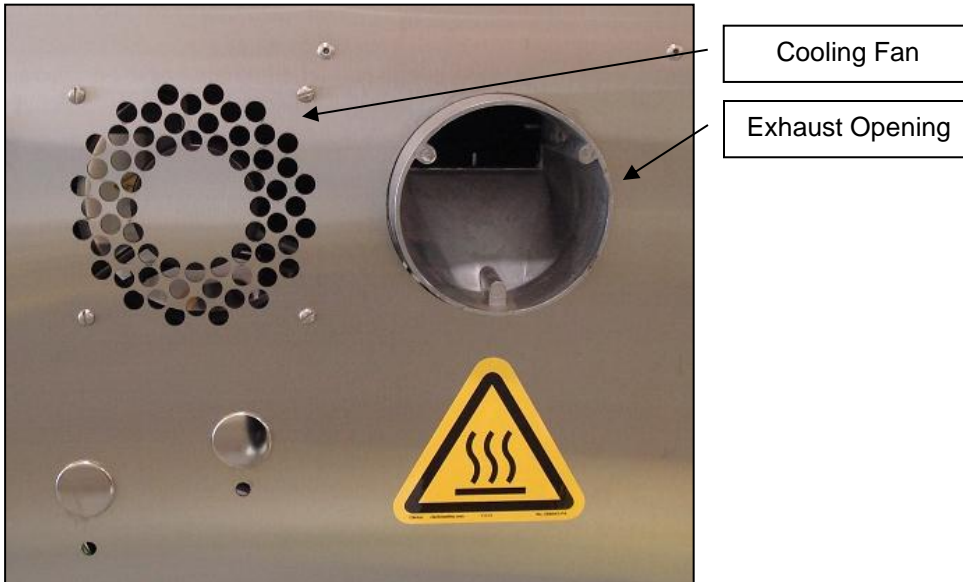

Figure 9. Exhaust Connections.

Notice	<i>Do not cover cabinet cooling fan. The cooling fan is required for lower compartment ventilation.</i>
---------------	--

	<i>Make sure exhaust piping materials can withstand maximum exhaust temperatures (Table 4).</i>
---	--

Table 4. Exhaust Connection Requirements.

Connection	LCC/LCD2-14
Exhaust Opening Diameter	4.0" (10.16cm)
Exhaust Fan	85
Maximum Temperature (LCC Series) (LCD Series)	260°C 350°C

Copyright © 2013 by Despatch Industries.

All rights reserved. No part of the contents of this manual may be reproduced, copied or transmitted in any form or by any means including graphic, electronic, or mechanical methods or photocopying, recording, or information storage and retrieval systems without the written permission of Despatch Industries, unless for purchaser's personal use.

4.2.4. Wiring & Power Connections

	<p>Danger!</p> <p><i>Contact with energized electrical sources may result in serious injury or death. All wiring to be completed by properly trained and licensed personnel.</i></p>
---	---

	<p><i>The oven must be hardwired directly to the disconnect switch on the equipment panel (Figure 11).</i></p>
---	--

	<p>Danger!</p> <p><i>All grounding and safety equipment must be in compliance with applicable codes, ordinances and accepted safe practices.</i></p>
---	---

A conduit fitting for customer power line is located on the rear left of the oven (Figure 10). This conduit runs up to the front control panel, where wires can terminate at the disconnect switch.

- Locate the conduit and run power (Figure 10 and Figure 11). Consult electrical drawings included with the oven for details (Section 8.4).
- Connect the line voltage power to the disconnect switch labeled **LINE CONNECTIONS** (Figure 11).



Figure 10. Line Connection.

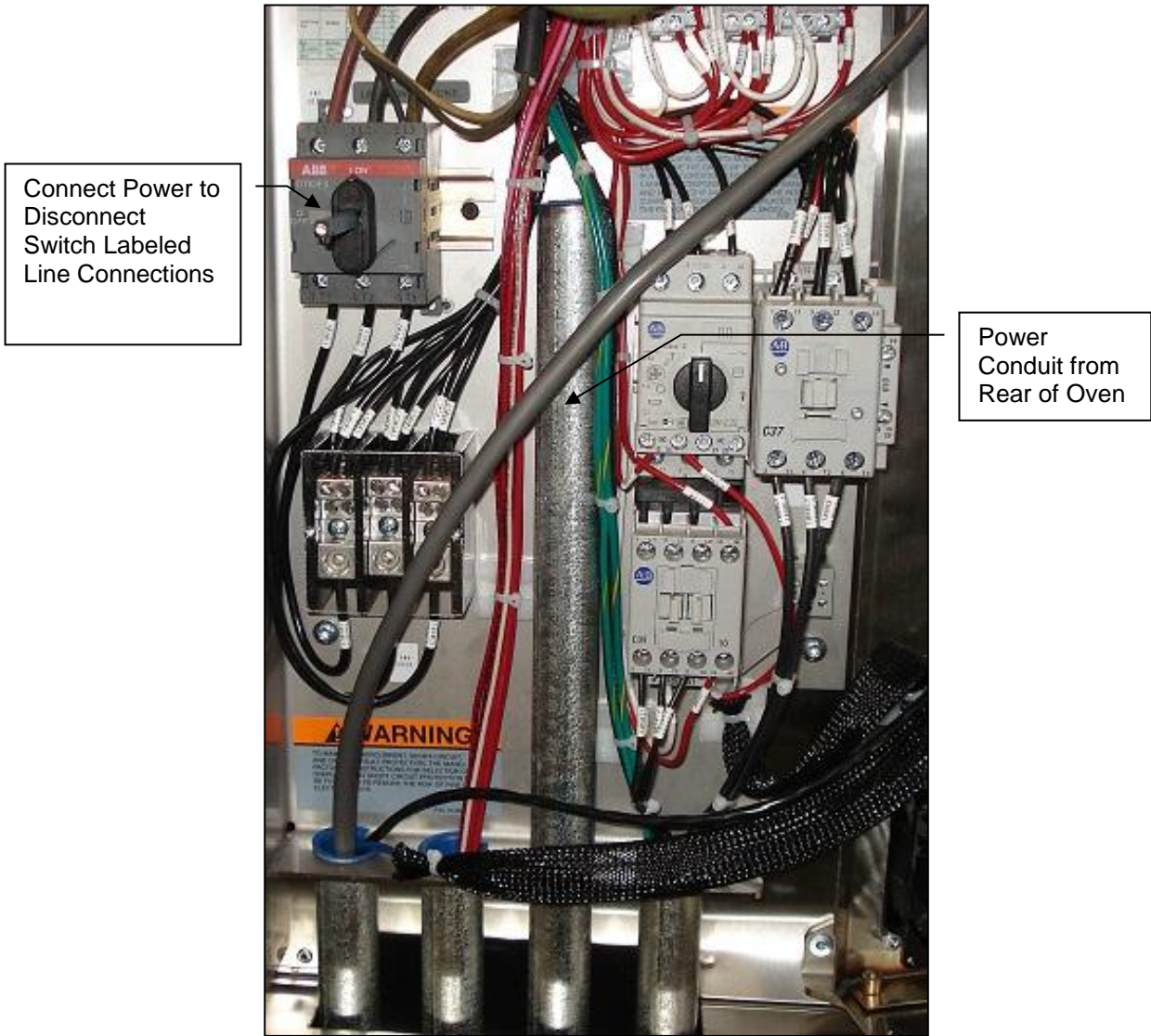



Figure 11. Conduit and Disconnect Switch/Line Connections.

Copyright © 2013 by Despatch Industries.

All rights reserved. No part of the contents of this manual may be reproduced, copied or transmitted in any form or by any means including graphic, electronic, or mechanical methods or photocopying, recording, or information storage and retrieval systems without the written permission of Despatch Industries, unless for purchaser's personal use.

4.3. HEPA Filter Installation

Not all LCC/LCD2-14 ovens come equipped with a HEPA filter. This HEPA filter installation section applies only to ovens designed for ISO Class 5 (Class 100) use, which are equipped with a HEPA filter. For a complete explanation of model numbers, refer to Section 1.5.1. Two different types of filters are typically used. While both filters are high-temperature filters in that they are designed for use in thermal processing equipment, the “standard” HEPA filter is rated to 260°C (500°F) while the “high-temperature” HEPA filter is rated to 350°C (662°F).

	<p>Each LCC/LCD2-14 oven uses one of two types of HEPA filters, depending on the oven's maximum temperature. Ovens that can be heated to 260°C (500°F) use the Standard HEPA filter. Ovens that can be heated to 350°C (662°F) use the High-Temperature HEPA filter.</p> <p>However, customers requiring a higher ramp rate while operating equipment below 260°C (500°F) may still choose to use the high-temperature HEPA filter:</p> <ul style="list-style-type: none">• Standard HEPA filter ramp rate: 1.25°C (34.25°F)/minute• High-Temperature HEPA filter ramp rate: 5°C (41°F)/minute
---	---

	<p>Warning!</p> <p>Make certain power is disconnected from the oven before removing or replacing the HEPA filter. Observe all applicable safety procedures.</p>
--	---

	<p>Caution!</p> <p>The HEPA filter is fragile. Take care to avoid damage during installation. If a filter unit is dropped, whether in the carton or not, examine it carefully for damage.</p>
---	---

	<p>Caution!</p> <p>The HEPA filter must be installed so that unfiltered air cannot leak past the unit.</p> <p>In general, defer to installation instructions provided by the filter manufacturer.</p>
---	--

4.3.1. HEPA Filter Handling and Inspection

1. Remove new filter from carton

	<p>Sweep floor clear of nuts, bolts and other protrusions which may damage the unit.</p> <p>Do not drop or jar the filter carton.</p>
---	---

<p>Notice</p>	<p>Do not attempt to repair the damaged filter unit—particularly the medium. Any unit so repaired must be retested to assure that hidden damage does not exist which might reduce filtering efficiency. Repair and retest is not economical for most users.</p>
----------------------	--

- a. Place carton on floor.
 - b. Tilt the carton on one corner. Handle the carton at opposing corners.
 - c. Remove sealing tape and fold back flaps of carton.
 - d. Gently unpend the filter to place the exposed end of the filter on the floor. Do not jar the filter.
 - e. Pull the carton from the filter unit. Be careful to not pull the filter from the carton.
2. Inspect the filter.
 - a. Visually inspect the new gasket (s) for damage during handling.
 - b. Use a strong lamp to examine the exposed areas of both faces for evidence of breaks, cracks, or pinholes (Figure 12). If a strong lamp is unavailable, use a flashlight in a darkened room.
 - c. Look for visible defects with the light projected along the full length of each channel created by the separators. Translucent spots may not necessarily indicate holes or cracks but may simply be variations in thickness of the filter medium.
 - d. Check that the adhesive seal around the filter unit faces are complete and unbroken.
 - e. Check frame corner joints for adhesive sealing and tightness.
 - f. Check that gaskets are cemented firmly to the filter frame and that gasket pieces are undamaged and butted or mated at the joints.



Figure 12. Example HEPA Filter (Silicone-free)



Opened pleats in the filter media are normal and result from the tempering process.

3. Pull shelves from the oven and set aside.



Danger!

Make certain power is disconnected from the oven before removing or replacing the HEPA filter.

Loosen screws to remove the entire inner casing assembly as a single unit.



Figure 13. LCC/LCD2-14 Side Panel.

4. Loosen screws at sides and top of supply duct/shelf supports on right side of chamber (Figure 13).
 - a. Pull out the shelf support/duct as a single unit and set it aside.
5. Remove the brass nuts and washers from the rods that are holding the filter frame in place.
 - a. Reuse these nuts to hold the filter in place.

Copyright © 2013 by Despatch Industries.

All rights reserved. No part of the contents of this manual may be reproduced, copied or transmitted in any form or by any means including graphic, electronic, or mechanical methods or photocopying, recording, or information storage and retrieval systems without the written permission of Despatch Industries, unless for purchaser's personal use.

- b. Discard the old filter in accordance with your company's disposal policies.
- c. Remove and discard the conduit spacers from the rods behind the filter frame.
- 6. Place the new filter in the oven:
 - a. For the High-temperature HEPA filter:
 - i. Place the filter with the triangular gasket set against the oven wall and the glass braid set against the clamping plate (Figure 14).
 - ii. Tighten the nuts until the triangular gasket is compressed to a thickness of 0.16 inch (0.4 cm).
 - b. For the Standard HEPA filter:
 - i. Place the filter with the gasket set against the oven wall (Figure 15).
 - ii. Tighten the four nuts alternately for a torque of 28 (+/- 3 in-lbs.).
 - iii. Be careful not to over tighten

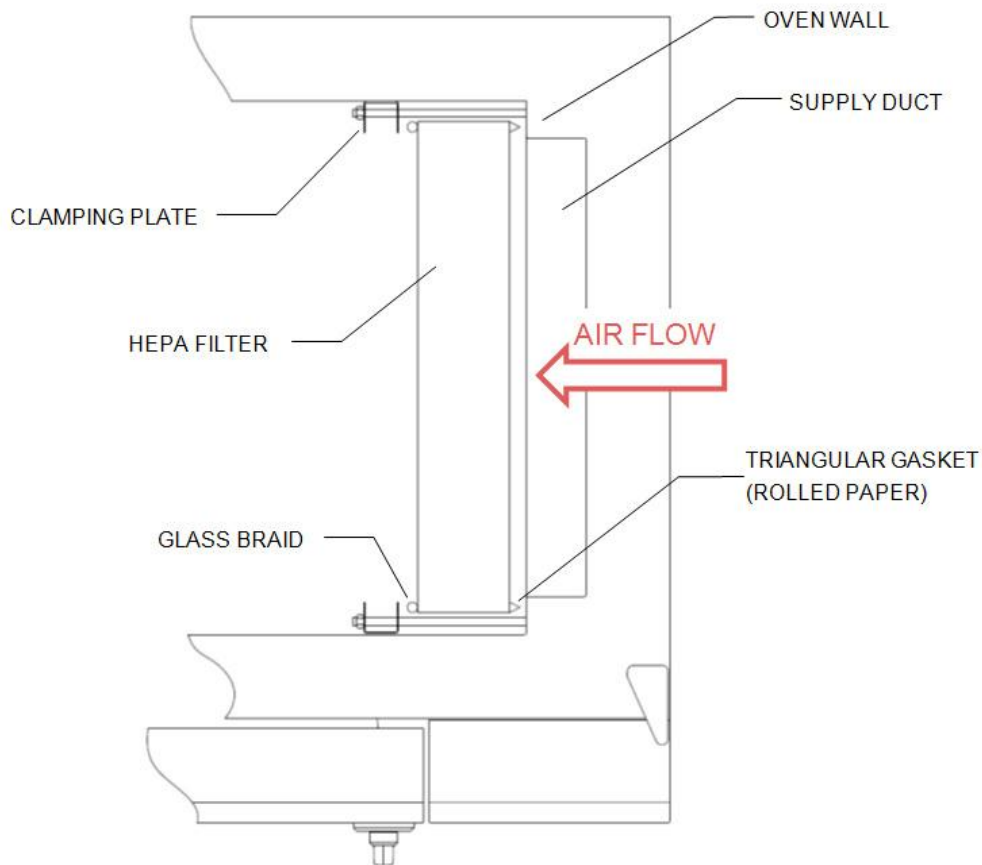

Figure 14. Install HEPA high-temperature filter.

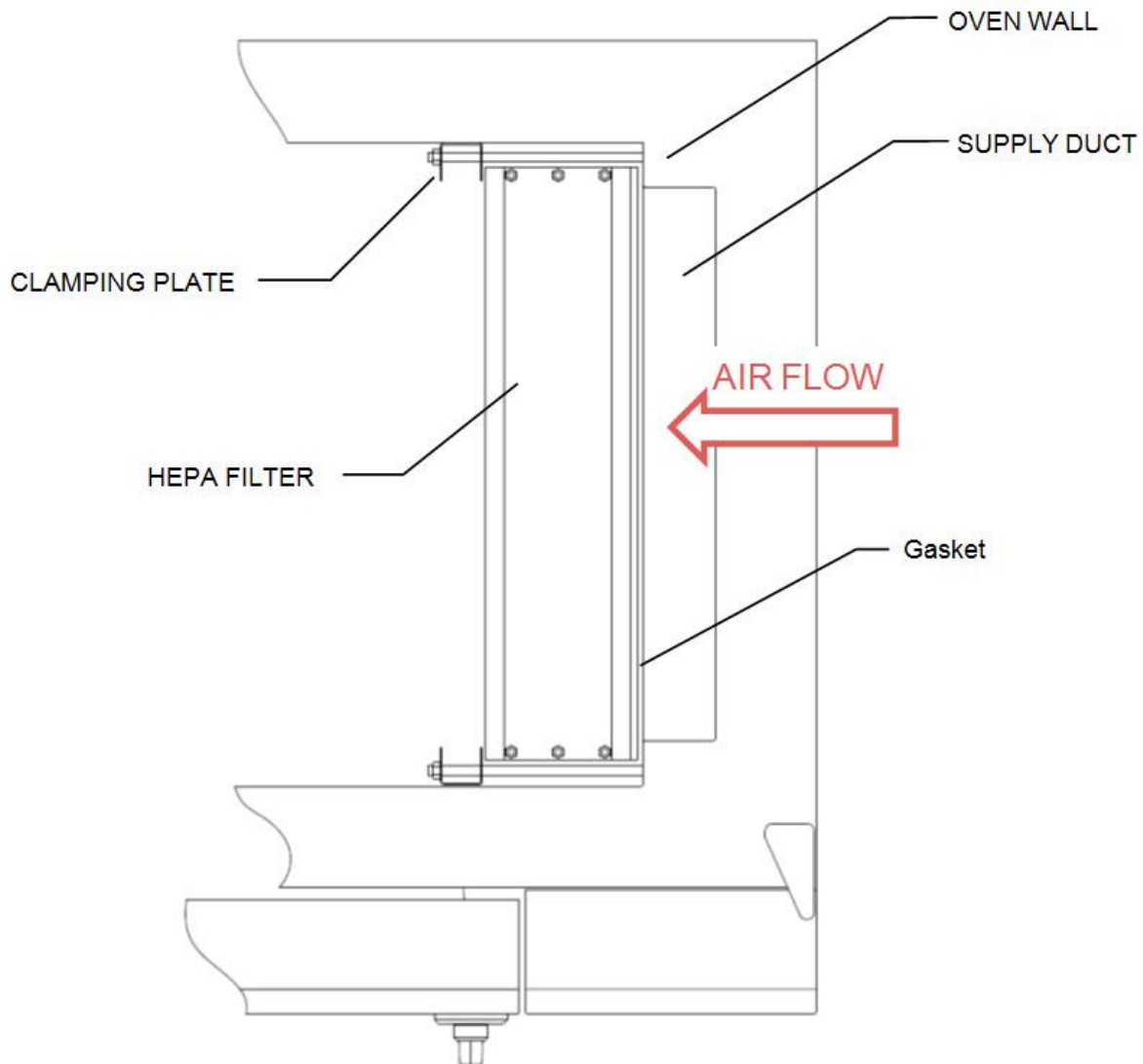



Figure 15. Install HEPA standard filter.

7. Reinstall filter frame using the nuts removed earlier.
 - a. Make sure the filter face is tight against the inside perimeter of the frame on all sides.
8. Reinstall the brass nuts and washers to tighten the filter frame down.
 - a. Tighten the nuts alternately for even tightness.
 - i. Be careful not to over tighten. Correct installation torque is 28 +/- 3 in-lbs (3.16 ± .33 N-m).
 - ii. Be sure to compress the gasket evenly and equally at all points with the filter frame completely covering the opening.
9. Reinstall shelf support/duct assembly using the screws removed earlier.
10. Reinstall oven shelf.

4.3.2. HEPA Filter Burn-Off

4.3.2.1. HEPA Filter Burn-Off Process

The burn-off process takes place in any equipment where a new HEPA filter is used at temperatures above 180°C (356°F). Expect smoke, possibly a pungent odor and a light residue on interior surfaces. This results from oxidation of the binder. Most of the binder will leave the filter after running at a temperature of 260°C (500°F) for 48 hours. Check the oven for particles or the exhaust for smoke and odor to determine that the process is finished.

	<p>While the high-temperature filter has undergone tempering treatment at the factory, smells and/or fumes may be released during the first use at temperature.</p>
---	--

4.3.2.2. Location of HEPA Filter Burn-Off Process

Select a location for the burn-off process where generated smoke and odor will be ventilated with the least amount of interruption and inconvenience. Ideally this will be in the final location for the oven. However, it may be a receiving dock, some well-ventilated space or even outside if the weather is acceptable. If this location is a very clean area, pay special attention to an exhaust hook-up that fully captures the smoke and odor produced. The post burn-off cleaning (that is, oven wipe down) may also generate dust.

4.3.2.3. Recommended HEPA Filter Burn-Off Process

	<p>LCC oven chamber temperature transitions must not exceed 1.5°C/minute to maintain class 100 chamber conditions. For ramp rates greater than 1.5°C/minute and up to 5°C/minute, the LCD model will maintain class 100 chamber conditions.</p>
---	--

1. Locate the equipment exhaust opening where chamber air is being expelled.
 - a. If the oven filter is burned off in a clean area, be sure to handle the equipment exhaust appropriately.
 - b. If the equipment is large and the exhaust stack is a permanent service connection, connect the equipment and exhaust stack before the burn-off process.
 - c. If the equipment is small with no permanent exhaust duct required, arrange a temporary connection out of the clean area that will handle the maximum temperature of the equipment. Direct the smoke and odor outside, or to a highly ventilated area.
2. Set the temperature control at the maximum process temperature.
 - a. Silicone: Ramp at 1.25°C/min to 260°C and soak for 48 hours.
 - b. Media Pack: Ramp at 1.25°C/min to 260°C and soak for 48 hours.
 - c. Termikfil: Ramp at 5°C/min to 350°C and soak for 48 hours.
3. Start the fan after making the electrical power connections.
4. Energize the equipment heater.

Copyright © 2013 by Despatch Industries.

All rights reserved. No part of the contents of this manual may be reproduced, copied or transmitted in any form or by any means including graphic, electronic, or mechanical methods or photocopying, recording, or information storage and retrieval systems without the written permission of Despatch Industries, unless for purchaser's personal use.

- a. Use enough fresh air to remove the smoke, while still being able to achieve and maintain the necessary temperature.
- b. The completion of the burn-off period should be based on the particle level in the oven or smoke-free exhaust and minimal odor level.
- c. Check the filter hold-down nuts after burn-off and tighten as necessary.
- d. For best oven particle control, this step should be repeated on a regular basis.

	<p><i>If the equipment must be moved after the burn-off process, use considerable care.</i></p> <ul style="list-style-type: none"> • <i>The binder which strengthened new filters is now burned-off and the media is very fragile.</i> • <i>Rough handling of either the filter alone or the equipment with the filter installed is not recommended as it may tear the media and lead to reduced filter efficiency.</i> • <i>Removal of the filter after heating can also result in damage to the frame seal, and is only recommended when replacing the filter.</i>
---	---

4.3.3. Filter High Limit Controller

The LCC/LCD2-14 Series have a redundant High Limit device to protect the HEPA filter (Figure 16). The sensor for the High Limit controller is located before the air inlet of the HEPA filter. The High Limit device is located in the lower compartment of the oven. If oven temperature exceeds the factory set Filter High Limit temperature, the High Limit controller will trip, shutting down the heater and protecting the HEPA filter.

4.3.3.1. Reset the High Limit Controller

Determine the cause of the excessive temperature before resetting the High Limit controller. Under normal operating conditions the Filter High Limit controller should never trip.

	<p><i>Determine the cause of the excessive temperature before resetting the High Limit controller.</i></p>
---	---

To reset the High Limit controller:

1. Remove the access panel to the lower compartment.
The High Limit is located next to the transformer.
2. Press the **RESET** button on the High Limit controller.
See the MIC1162 reference manual for the operation of this High Limit.



Figure 16. Typical High Limit controller. Note RESET button on right.

5. Operation

	<p><i>Users and operators of this oven must comply with operating procedures and training of operating personnel as required by the Occupational Safety and Health Act (OSHA) of 1970, Section 5 and relevant safety standards, and other safety rules and regulations of state and local governments. Refer to the relevant safety standards in OSHA and National Fire Protection Association (NFPA), Section 86 of 1990.</i></p>
---	--

	<p>Danger!</p> <p><i>LCC/LCD2-14A Class A ovens are designed for a specific amount of solvent. Exceeding this amount could result in an explosion. Do not process closed containers of any substance or liquid in this oven because they may explode under heat. In case of fire, leave door(s) as they are. Shut off electricity. Shut off fuel. Call the fire department. Stay away.</i></p>
---	---

5.1. Load Oven

	<p><i>Despatch Industries cannot be responsible for either the process or process temperature used, or for the quality of the product being processed. It is the responsibility of the purchaser and operator to see that the product undergoing processing in a Despatch oven is adequately protected from damage.</i></p> <p><i>Carefully following the instructions in this manual will help the purchaser and operator in fulfilling that responsibility.</i></p>
---	---

Avoid spilling on the heater elements or oven floor when loading the oven. Do not place the load on the oven floor plate. Placing the load on the oven floor may cause the load to heat unevenly and the weight may cause shorting out of the heater elements. Use the shelves provided.

	<p>Caution!</p> <p><i>Always place loads on the shelves provided to avoid possible uneven heating and damage to the oven.</i></p>
---	--

Copyright © 2013 by Despatch Industries.

All rights reserved. No part of the contents of this manual may be reproduced, copied or transmitted in any form or by any means including graphic, electronic, or mechanical methods or photocopying, recording, or information storage and retrieval systems without the written permission of Despatch Industries, unless for purchaser's personal use.

The two shelves are designed to be pulled out about halfway without tipping. Do not overload the shelves. Distribute the workload evenly so airflow is not restricted. Do not overfill your oven. The workload should not take up more than two-thirds of any dimension of the inside cavity.

5.2. Pre-Startup Checklist

- Know the system. Read this manual carefully. Make use of its instructions and explanations. Safe, continuous, satisfactory, trouble-free operation depends primarily on your degree of understanding the system and your willingness to keep all parts in proper operating condition.
- Check line voltage. Voltage must correspond to nameplate requirements of motors and controls. A wrong voltage can result in serious damage. Refer to Section 1.5.4 for more information.
- Check fresh air and exhaust openings. Do not be careless about restrictions in and around the fresh air and exhaust openings and stacks. Under no condition can they be permitted to become so filled with dirt that they reduce airflow.



Warning!

Do not use flammable solvent or other flammable material in this oven if it is not Class A. Do not process closed containers of any substance or liquid in this oven because they may explode under heat.





For LCC/LCD2-14 Class A ovens, the purge timer is preset with the time listed on the nameplate at the factory.

5.3. Operating Procedure

5.3.1. Start The LCC/LCD2-14 Oven

1. Turn the yellow/red **DISCONNECT SWITCH** to ON (Figure 17).
2. Press the **POWER** for ON.
 - a. The door remains unlocked.

	During the process cycle the door is locked. To unlock the door press STOP or remove power from oven using the DISCONNECT SWITCH.
---	--

	For Optional Beacon Light-equipped Units Only: The amber (center) beacon light will illuminate, indicating that the oven is ready to receive work to be processed (Figure 7).
---	--

	For LCC/LCD2-14 Class A ovens: Once the power switch is turned one and the recirculation fan and exhaust fan are turned on, the airflow switch will actuate and the purge timer will begin timing. The heater will not turn on and the oven will not begin heating until the purge period is complete.
--	---

3. The heater is wired in series with the door switch. The door must be completely closed and locked to activate the heater.



Figure 17. Power the LCC/LCD2-14 Oven.

Copyright © 2013 by Despatch Industries.

All rights reserved. No part of the contents of this manual may be reproduced, copied or transmitted in any form or by any means including graphic, electronic, or mechanical methods or photocopying, recording, or information storage and retrieval systems without the written permission of Despatch Industries, unless for purchaser's personal use.

5.3.2. LCC/LCD2-14 Class A Oven Operation

1. Verify the purge time with the time listed on the nameplate (Figure 18).
2. Turn the yellow/red **DISCONNECT SWITCH** to ON (Figure 17).
3. Press the **POWER** for ON.
4. Close the main disconnect switch.
5. Press the **START** push button.
6. Start the profile. The exhaust fan will start, the airflow switch will actuate, and the purge timer will begin timing.
7. When the purge period is complete, the oven will begin heating.

Despatch	
MODEL :	LCC2-14A-3
SERIAL NUMBER:	180714
MAX TEMP:	500°F / 260°C
VOLATILE:	0.06 GPH MEK OR EQUAL @ 350°F / 177°C.
PURGE TIME:	3 MINUTES
POWER:	380V-3PH-50HZ 28.9 AMPS (SCCR-5KA)
HEATER:	15.1KW, 22.9 AMPS
MOTOR:	1.50HP REC 2.5 AMPS 380V 0.03HP EXH 1.1 AMPS 120V
ELEC DWG #:	DA396-303571*
SERVICE (U.S.): 1-800-473-7373	
SERVICE (INT): 1-800-469-8230	
WEBSITE: WWW.DESPATCH.COM	

Figure 18. Class A Nameplate Example.



Danger!

LCC/LCD2-14A Class A ovens are designed for a specific amount of solvent. Exceeding this amount could result in an explosion. Do not process closed containers of any substance or liquid in this oven because they may explode under heat. In case of fire, leave door(s) as they are. Shut off electricity. Shut off fuel. Call the fire department. Stay away.

5.3.3. Working with Protocol 3 Operating Modes

Refer to the Protocol 3 Controller Owner's Manual for specific information for working with the controller.

5.3.4. Sequence of Operation for LCC/LCD2-14 Ovens Equipped with Optional Beacon Light

1. After starting the oven (refer to Section 5.3.1), the Protocol 3 controller initializes.

Copyright © 2013 by Despatch Industries.

All rights reserved. No part of the contents of this manual may be reproduced, copied or transmitted in any form or by any means including graphic, electronic, or mechanical methods or photocopying, recording, or information storage and retrieval systems without the written permission of Despatch Industries, unless for purchaser's personal use.

- a. The oven should be idle, empty, with the door closed and awaiting the next lot for processing.
- b. The Protocol 3 Controller should not be running a profile.
2. Open the oven door.

	<i>The amber beacon light (Error! Reference source not found.) will be ON (steady) until the profile is started (at the completion of Step 5).</i>
---	---

3. Place the product on the shelf in the oven.
4. Close the oven door.
5. Run the desired profile with the Protocol 3 Controller.

	<i>Press Run at any time to activate the Profile Mode.</i>
---	---

- a. Press **Select** until **Profile** is displayed.
- b. Press **▲** or **▼** to display the desired profile.
- c. Press **Run** to start the Profile Mode.

	<i>After pressing Run, the display changes from Stop to Run. Segment time remaining and Current Segment number will display.</i>
--	---

6. At this point, the oven profile cycle is in process and the door is locked.
 - a. The green beacon light is ON (steady), the amber beacon light is off.
 - b. When the process is complete, the amber beacon should be ON, and the door is unlocked.
7. Close the oven door to complete the process cycle. The oven is ready for the next lot.

5.3.5. Sequence of Operation for Ovens Equipped for LCC/LCD2-14 Inert Atmosphere Oven

	<p>Danger!</p> <p><i>Suffocation can occur in a nitrogen-atmosphere oven chamber if it is not thoroughly purged with room air before a person goes inside it.</i></p> <p><i>Before entering an oven chamber run the oven for at least five minutes with the nitrogen (or any other inert gas) turned off, doors open and recirculation fan running.</i></p> <p><i>Do not work inside oven with the doors closed if you have not purged the chamber with nitrogen (or any other inert gas) first.</i></p>
---	---

1. After starting the oven (Section 5.3.1), the Protocol 3 controller initializes.

	<p>Refer to the Protocol 3™ Controller Owner's Manual for more information on programming event outputs.</p>
---	---

2. The oven should be idle, empty, with the door closed and awaiting the next lot for processing.
3. The Protocol 3 Controller should not be running a profile.
4. Open the oven door.
5. Place the product on the shelf in the oven.
6. Close the oven door.
7. Run the desired profile with the Protocol 3 Controller.
 - a. Press **Select** until **Profile** is displayed.

	<p>Press Run at any time to activate the Profile Mode.</p>
---	---

- b. Press **▲** or **▼** to display the desired profile.
 - c. Press **Run** to start the Profile Mode.
8. The first segment of the program is the PURGE MODE.
 - a. Set the nitrogen flow meter (Figure 19) to 300-350 scfh.
 - b. This program energizes the purge solenoid valve.
 9. The second segment is the MAINTAIN MODE:
 - a. The purge solenoid valve is de-energized and the maintain solenoid is energized to maintain the nitrogen level to less than the purge level.
 - b. Adjust the needle valve located in the front bottom of the oven (Figure 20). Leave the maintain valve energized as long as the nitrogen level is maintained.



Figure 19. Nitrogen Flowmeter.



Figure 20. Adjust Nitrogen needle valve (in compartment beneath oven).

10. The third and final segment is the COOLDOWN MODE. In Cooldown mode, water valves are energized to bring the chamber to a safe unloading temperature.
 - a. Set water cooling flow meter to 3 GPM (11 LPM), and adjust if necessary.
 - b. Water cooling flowmeter is located on the lower left side of the oven.

5.3.6. Main Disconnect and Manual Unlock

5.3.6.1. Main Disconnect Switch

This disconnect switch (Figure 21) is connected to the load break switch behind the panel that disconnects or connects power from the main line.





Figure 21. Main Disconnect Switch.

	<p>Both the LCC/LCD2-14 oven and the LCC/LCD2-14PT-3 Pass-Through oven have a disconnect switch on the front control panel door.</p>
--	---

5.3.6.2. Manual Unlock

If a power failure occurs insert a torx tip tool (provided) and rotate 90 degrees counterclockwise to allow the chamber door to open. The tool must be turned back to the locked position to allow electrical operation again.

	<p>Warning!</p> <p><i>The LCC/LCD2-14 door requires a Manual Override Key for use when power is OFF. The door and panel that require a tool to open are part of the safety system of the LCC/LCD2-14 Oven. Do not attempt to permanently mount the Manual Override Key.</i></p>
---	--

	<p>Do not remove torx screw from door release mechanism. Manual Override Key cannot be permanently mounted.</p>
---	--

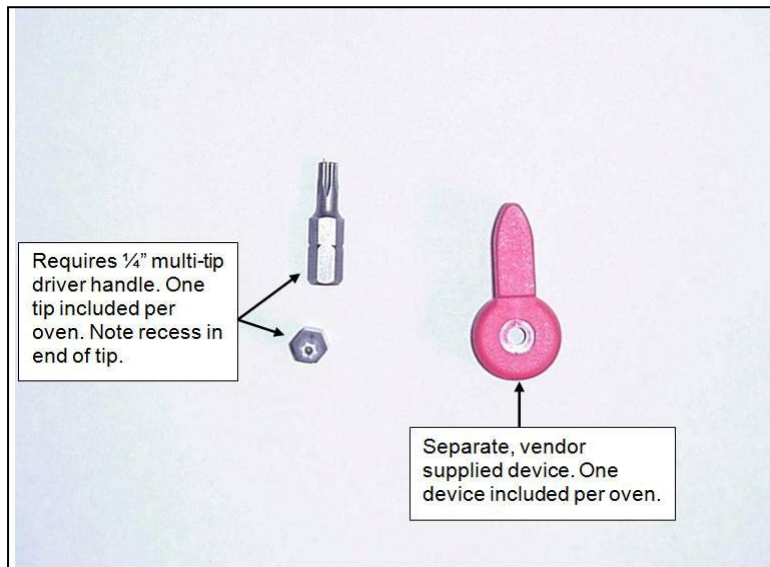



Figure 22. Door Lock Manual Override Key (LCC/LCD).

6. Maintenance

Do not attempt any service on this oven before opening the main power disconnect switch.

	<p><i>Danger!</i></p> <p><i>Disconnect all power sources before making repairs. Contact with energized electrical sources may result in serious injury or death.</i></p>
---	--

6.1. Checklist

- Keep equipment clean. Gradual dirt accumulation retards airflow. A dirty oven can result in unsatisfactory operation such as unbalanced temperature in the work chamber, reduced heating capacity, reduced production, overheated components, and the like. Keep the walls, floor and ceiling of the oven work chamber free of dirt and dust. Floating dust or accumulated dirt may produce unsatisfactory work results. Keep all equipment accessible. Do not permit other materials to be stored or piled against it.
- Protect controls against excessive heat—particularly controls, motors or other equipment containing electronic components. Temperatures greater than 50°C (122°F) should be avoided.
- Establish maintenance and checkup schedules. Do this promptly and follow the schedules faithfully. Careful operation and maintenance will be more than paid for in continuous, safe and economical operation.
- Maintain equipment in good repair and make repairs immediately to avoid costly delays.
- Practice safety. Make it a prime policy to know what you are doing before you do it. Make **caution, patience, and good judgment** the safety watchwords for the operation of your oven.
- Inspect oven seals if pressure readings decrease over time (Refer to Section 3.3.5 as well as Table 6, Columns D and/or E)

	<p><i>Danger!</i></p> <p><i>For LCC/LCD2-14A Class A ovens: Do not allow flammable solvents, combustibles, or other organic material to accumulate in Class A ovens, as this could lead to fire or explosion, particularly if the maximum solvent rating of the oven is exceeded.</i></p>
---	---

6.2. Maintenance Schedule

Preventive Maintenance (Refer to Section)	Daily	Weekly	Monthly	Every Three Months	Every Six Months	Annually	As Needed
General							
Avoid placing load too close to supply duct (5.1)	X						
Visually inspect for dirt, debris and free movement of parts and controls.				X			
Clean as needed							X
Inspect door seals for proper seating, damage and/or tears			X				
Inspect door operation. Doors should open and close securely, without jerking or slamming.			X				
Check Main Disconnect Switch (2.5.1)					X		
Time to temperature: record heating times for similar loads. If heating times are slowing, it could indicate a need for maintenance.			X				
Ventilation							
Inspect HEPA filter (if equipped) installation direction (4.3)						X	
Inspect HEPA filter (if equipped) (6.4.1)						X	
Electrical							
Check High limit controller (6.6)				X			

Copyright © 2013 by Despatch Industries.

All rights reserved. No part of the contents of this manual may be reproduced, copied or transmitted in any form or by any means including graphic, electronic, or mechanical methods or photocopying, recording, or information storage and retrieval systems without the written permission of Despatch Industries, unless for purchaser's personal use.

6.3. Lubrication

Fan motor bearings are permanently lubricated. All door latches, hinges, door operating mechanisms, bearing or wear surfaces should be lubricated to ensure easy operation.

6.4. HEPA Filter Replacement

Refer to Section 4.3 for filter replacement.

6.4.1. Routine HEPA Filter Inspection

Section 4.3.1 provides more detail about HEPA filter handling and inspection prior to installation.

1. In general, inspect for cracks, breaks or pinholes. Replace as necessary.
2. Measure the pressure drop across the HEPA filter. When the pressure is greater than 1" w.c. than when installed, Despatch recommends replacing the filter.

6.5. Cleaning and Decontamination

6.5.1. Cleaning the LCC2-14 Series Oven

	<p>Warning!</p> <p><i>Do not clean oven without first disconnecting power.</i></p>
---	---

For best product results, clean the oven monthly. To clean the oven:

1. Wipe all surfaces with a moistened towel or use a neutral cleaning agent.
2. Use a moistened towel to remove cleaning agents when finished.
3. Dry oven completely before turning it on again.

Clean stainless steel surfaces quarterly. To clean stainless steel surfaces:

1. Remove stains or spots with MEK (Methyl-Ethyl-Ketone).
2. Immediately after using MEK, wash steel surface using a polyurethane cloth or sponge with clean water and liquid detergent.

<p>Notice</p>	<p>Clean quickly for maximum surface protection.</p> <p>Using water that contains chlorine or hydrochloric acid to clean may damage the oven. Choose a neutral cleaning agent instead.</p>
----------------------	--

6.5.2. Decontaminating the LCC2-14 Series Oven



Warning!

Do not decontaminate oven without first disconnecting power. Ensure adequate personal safety while decontaminating oven.

Notice

Before using any cleaning or decontamination method except those recommended by the manufacturer, users should check with the manufacturer that the proposed method will not damage the equipment.

For best results, decontaminate the work zone daily.

1. Wipe all work surfaces with an appropriate disinfectant.
2. Use a neutral cleaning agent. Do not use acidic or chlorine cleaning detergents as they may damage or corrode the oven.



If necessary, remove highly contaminated inner chamber parts for cleaning or exchange.



Danger!

Explosive gases may form during decontamination. Dry and ventilate oven before start-up to avoid explosions.

6.6. Check High-Limit Controller

The Protocol 3 controller has an integrated high limit function which disables the heater output when tripped. Check the High Limit controller by:

1. Set the Hi-Limit setpoint below the process temperature. Refer to the Protocol 3 manual as necessary.
2. The oven should heat and trip the High-Limit controller as it reaches the high limit setpoint.
3. If not, contact Despatch.

Copyright © 2013 by Despatch Industries.

All rights reserved. No part of the contents of this manual may be reproduced, copied or transmitted in any form or by any means including graphic, electronic, or mechanical methods or photocopying, recording, or information storage and retrieval systems without the written permission of Despatch Industries, unless for purchaser's personal use.

7. Troubleshooting: Error Messages and Alarm

Table 5 lists the more common error messages, possible problems and remedies.

Table 5. Error Messages and Next Steps.

Alarm Status	Possible Problem	Next Step
HI LIMIT LED ON	<ul style="list-style-type: none"> • Problem with thermocouple • High Limit setpoint has been exceeded 	Once the problem has corrected, press RESET .
DEV HOLD LED flashing	Oven temperature has not entered (or dropped out of) the Auto Hold band and the soak timer has stopped	Program a slower ramp rate or, if oven is not heating check heater circuit.
Top PV displays OPEN	Control thermocouple is disconnected or broken	Repair or replace the thermocouple.
HLPV displays OPEN	High Limit thermocouple is disconnected or broken	Repair or replace the thermocouple.

Copyright © 2013 by Despatch Industries.

All rights reserved. No part of the contents of this manual may be reproduced, copied or transmitted in any form or by any means including graphic, electronic, or mechanical methods or photocopying, recording, or information storage and retrieval systems without the written permission of Despatch Industries, unless for purchaser's personal use.

8.2. LCC/LCD2-14 Series Oven Options

8.2.1. Optional MRC5000 Setup

	Refer to instructions provided recorder manufacturer for more specific installation notes.
---	---

Temperature is retransmitted to the MRC5000 recorder from the controller. To set up the recorder:

1. Ensure hardware jumper JU1 is in place for the 5 VDC setting (Refer to MRC5000 Manual included).
2. Move MODE to **PROG/TEST/CAL** to display **Prog.**
3. Press ▼ twice to display **Inps**. Move to each Parameter Code using ▼ or ▲. Adjust each Parameter Code using the settings in Table 7.
4. After adjusting all settings, move MODE to **RUN**. Display on both the recorder and controller should read the same.

Table 7. MRC 5000 Settings.

Parameter Code	Degrees C	Degrees F
Inps	18	18
Icor	0	0
diSP	On	On
dPOS	0	0
EUU ⁶	400	752
EUL ⁶	0	32
ChUP	400	800 ⁷
ChLO	0	0
DFF	1	1

8.2.2. Optional High Limit Alarm with Alarm Silence

The LCC/LCD2-14 Series oven optional High Limit Alarm provides an audible and visual alarm when the temperature exceeds the High Limit setpoint on the control. The alarm horn is typically located to the right of the control panel door.

⁶ These values must match the settings **RetOutLo** and **RetOutHi** on the Protocol 3 Control page. For example, if **RetOutLo** is 32, **EUL** must read 32.

⁷ Change 0-400 chart paper to 0-800 chart paper. Depending on the equipment used, 0-600 paper may be used if the maximum temperature is 500°F.

When the chamber temperature exceeds the High Limit setting on the control, the heater shuts down, the alarm horn sounds and the red push button switch will illuminate.

To silence the alarm:

1. Depress the **Alarm Silence** switch (Figure 23).
 - a. This silences the alarm horn.
 - b. The red push button switch remains illuminated.

	<p>Optional Beacon Light-equipped Units: The red (top) beacon light will illuminate, indicating a fault has occurred (Error! eference source not found.).</p>
---	--

2. Clear the alarm by correcting the High Limit condition.
3. When the High Limit condition clears, press **Reset** on the control. See Protocol 3 Owner's Manual for detailed operation.
4. The red push button switch will go off, the heater switches on and the control is functioning correctly.
5. If the High Limit trips repeatedly, identify the cause and correct the problem.



Figure 23. Alarm Silence Switch.

	<p>When the alarm is triggered by the end of cycle, the alarm will continue to be active until another process is started.</p>
---	---

8.3. Standard Products Warranty



Standard Products Product Warranty

Products Covered by this Warranty

This warranty (the "Warranty") applies to the following Despatch products: LEB, LBB, LAC, LCC, LCD, LLC, LLD, RAD, RFD, LND, TAD, TFD, PN, PTC, PCC, 900 Series.

Parts and Materials

Despatch warrants all parts and materials to be free from defects in material and workmanship for a period of:

1. five (5) years from date of shipment for laboratory oven electric heaters;
2. three (3) years from date of shipment for Protocol Plus, Protocol 3 and DES 2000 temperature controllers; and
3. one (1) year from the date of shipment, or 2,000 hours of operation, whichever occurs first, for all other components of products covered by this Warranty.

During the applicable Warranty period, Despatch will repair or replace, at Despatch's option, parts and materials covered by this Warranty

Labor

During the first 90 days of the Warranty period, Despatch will pay labor costs incurred to remove defective parts and materials, and to reinstall repaired or replacement parts or materials; provided, however, that Despatch's obligation to pay such labor costs shall be subject to the limitation that the removal and/or reinstallation service must be performed by a Despatch-authorized technician from Despatch's worldwide network of factory-trained professionals at a location within the contiguous United States.

Transportation Costs

All transportation costs to transport defective parts or materials to Despatch, and to transport repaired or replacement parts or materials to Customer, shall be the responsibility of the Customer.

Terms and Conditions

This Warranty shall be deemed valid and binding upon Despatch if and only if the Customer:

1. installs, loads, operates, and maintains the covered product supplied hereunder in accordance with the instruction manual provided upon delivery and product labeling affixed to the subject equipment;
2. if applicable, follows the Emergency Procedure set forth in this Warranty; and
3. contacts Despatch's Helpline at 1-800-473-7373 for assistance in diagnosing and troubleshooting the problem immediately upon discovering any damage or malfunction.

Despatch's reasonable determination as to whether a repair, replacement, or service is covered by this Warranty shall be final and binding.

Exclusions

This Warranty DOES NOT cover:

1. damage or malfunctions, or expenses incurred in the process of diagnosing and/or repairing damage or malfunctions, resulting from any of the following: operator error, misuse, abuse, inadequate preventive maintenance, normal wear and tear, service or modifications by other than Despatch

THE REPRESENTATION AND WARRANTIES SET FORTH HEREIN ARE EXCLUSIVE AND IN LIEU OF, AND CUSTOMER HEREBY WAIVES AND DISCLAIMS RELIANCE UPON, ALL OTHER REPRESENTATIONS AND WARRANTIES OF EVERY KIND WHATSOEVER, WHETHER EXPRESS OR IMPLIED, OR ARISING BY OPERATION OF LAW OR IN EQUITY, OR BY COURSE OF PERFORMANCE OR DEALING OR USAGE OF TRADE, INCLUDING, WITHOUT LIMITATION, ANY IMPLIED WARRANTIES OF MERCHANTABILITY OR OF FITNESS FOR A PARTICULAR PURPOSE.

THIS WARRANTY IS PERSONAL TO THE CUSTOMER AND MAY NOT BE TRANSFERRED OR ASSIGNED. ALL LIMITATIONS HEREUNDER, HOWEVER, SHALL BE BINDING ON ALL SUCCESSORS AND ASSIGNS OF CUSTOMER.

Service

Phone 800-473-7373; International Phone 952-469-8230; Fax 952-469-8193
e-mail service@despatch.com; www.despatch.com

Please see reverse side for other service offerings

BB7 (12/30/08)

authorized technicians, use of the covered product that is inconsistent with the operation manual or labeling, acts of nature (including, without limitation, floods, fire, earthquake, or acts of war or civil emergency), internal or external corrosion, or non-conforming utilities (including, without limitation, electrical, fuel supply, environmental and intake/exhaust installations);

2. repair or replacement of parts or materials designed and intended to be expendable or consumable; refrigerants, filters, lamps;
3. routine maintenance; or
4. labor costs incurred for troubleshooting, diagnostics, or testing (except for testing required to verify that a covered defective part or material has been repaired).

Limitations of Liability

Despatch shall not, in any event, be liable for indirect, special, consequential, incidental, or punitive damages or penalties of any kind, including, without limitation loss of revenue, profits or business opportunities resulting from interruption of process or production. In no event shall Despatch be liable for damages in excess of the amounts paid by Customer to Despatch with respect to the applicable product(s). This Warranty does not cover, and Despatch shall not be liable for any losses, costs, damages or expenses resulting from delays in diagnosing or repairing the products, supplying or obtaining replacement parts or materials, strikes, labor stoppages or shortages, fires, accidents, government acts or regulations, or any other causes beyond the control of Despatch.

Non-Compliance By Customer

Despatch reserves the right to suspend and withhold service under this Warranty in the event of non-compliance by the Customer to any terms and conditions of this Warranty or the applicable purchase order or invoice. Further, Despatch shall not be liable for any loss of production, expenses, and inconveniences incurred due to such suspension.

Customer Furnished Equipment Warranty Limitation

This Warranty does not cover diagnosis or repairs of defects in or caused by, lack of performance of, or fitness for purpose of customer-supplied parts or equipment unless specifically noted in the Despatch written order acceptance confirmation.

Performance Commitment

Despatch provides no guarantee of process performance or fitness for purpose, unless specifically noted otherwise in Despatch written order acceptance confirmation. Despatch is providing equipment with design parameters specific only to its equipment.

Procedure Upon Discovery of Defects and Emergencies

In the event Customer becomes aware of any defect in the applicable products, Customer must immediately: (a) shut off fuel or energy supply (gas and electricity), (b) call for emergency assistance, if needed, and (c) notify Despatch Service.

8.4. Electrical Schematics

The following pages contain electrical schematics for the LCC/LCD2-14 Series oven.

Copyright © 2013 by Despatch Industries.

All rights reserved. No part of the contents of this manual may be reproduced, copied or transmitted in any form or by any means including graphic, electronic, or mechanical methods or photocopying, recording, or information storage and retrieval systems without the written permission of Despatch Industries, unless for purchaser's personal use.

MINNEAPOLIS • SHANGHAI • BERLIN • SINGAPORE • HSINCHU

SERVICE AND TECHNICAL SUPPORT

Service parts: 1-800-473-7373
International service/main: 1-952-469-8230
Service fax: 1-952-469-8193
service@despatch.com

GLOBAL OFFICES

Germany: +49 30 629 073 410 / europe@despatch.com
China: +86-21-62365868 / shanghai@despatch.com
Taiwan: +886-3-6588484 / taiwan@despatch.com

USA HEADQUARTERS

Phone: 1-952-469-5424
US toll free: 1-888-337-7282
Fax: 1-952-469-4513
info@despatch.com
service@despatch.com

www.despatch.com

8860 207th Street West
Minneapolis, MN 55044 USA

Despatch
INDUSTRIES

© 2012 Despatch Industries. All rights reserved. Despatch is a registered trademark of Despatch Industries in the U.S. and other countries. No part of the contents of this manual may be reproduced, copied or transmitted in any form or by any means without the written permission of Despatch Industries, unless for purchaser's personal use.